



STRONG. PROFESSIONAL. DESIGN.[™]
S P E C I F I C A T I O N S

Bath Classics[™] Three Valve Compression Tub/Shower Faucet

Models 10221PQ, 10221, 10223PQ,
10261PQ, 10262PQ, 10921P

Standard Features

- Maximum operating input water pressure80 psi
- Maximum pressure125 psi
- Shower flow rate2.5 gpm at 80 psi
(see chart)
- Tub Filler flow rate8 gpm at 60 psi
- Maximum handle torque at 80 psi1.25 ft lbs
- Shower and tub spout output connectors1/2" IPS
- Valve TypeCompression valving

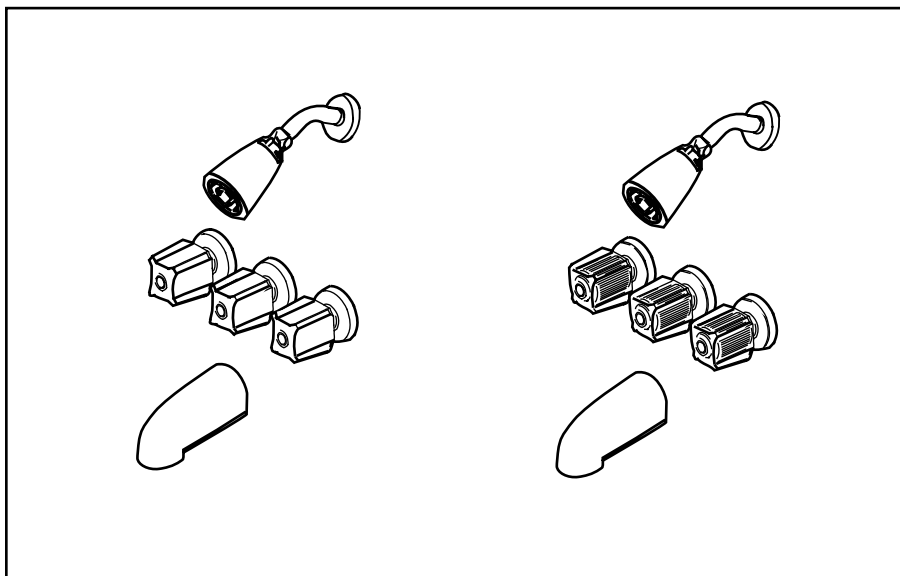

Standards and Ratings

- ASME A112.18.1M American Society of Mechanical Engineers Standard: "Plumbing Fixtures Fittings"

Features

Compression valving

Chrome plated

Choice of handles

Benefits

Ideal for hard water areas. Easy and inexpensive to maintain

Durable and easy to clean

Easy operation and unique style coordinates with traditional or contemporary decor

Optional Features

- | | | |
|--|---|---|
| <input type="checkbox"/> Acrylic Handles | <input type="checkbox"/> 1/2" IPS Connections | <input type="checkbox"/> With Stops Without Stops |
| <input type="checkbox"/> Blade Handles | | |

Bath Classics™
Three Valve Compression
Tub/Shower Faucet

Models 10221PQ, 10221, 10223PQ,
 10261PQ, 10262PQ, 10921P

D I M E N S I O N S

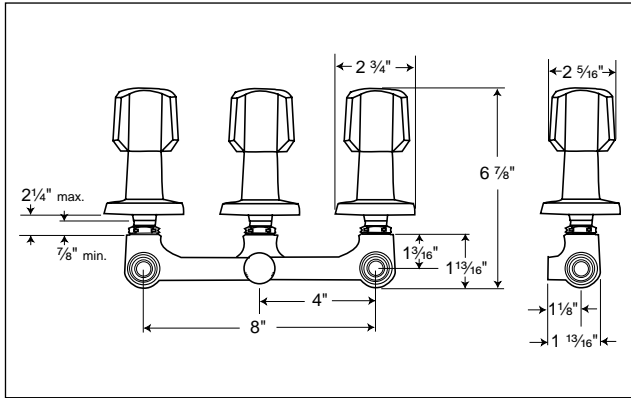

Three Valve Tub/Shower with Acrylic Handles

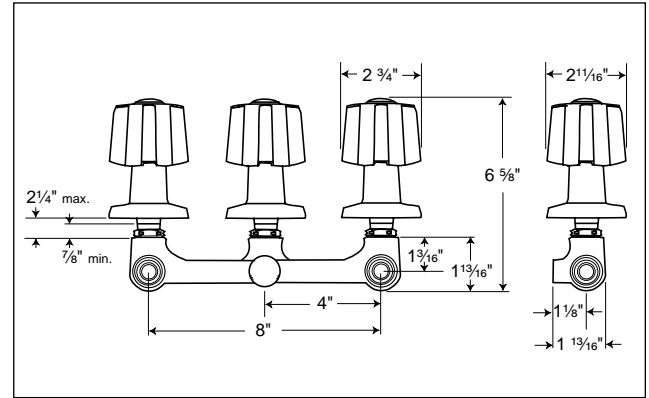

Three Valve Tub/Shower with Blade Handles

SHOWER FLOWRATE (gpm)

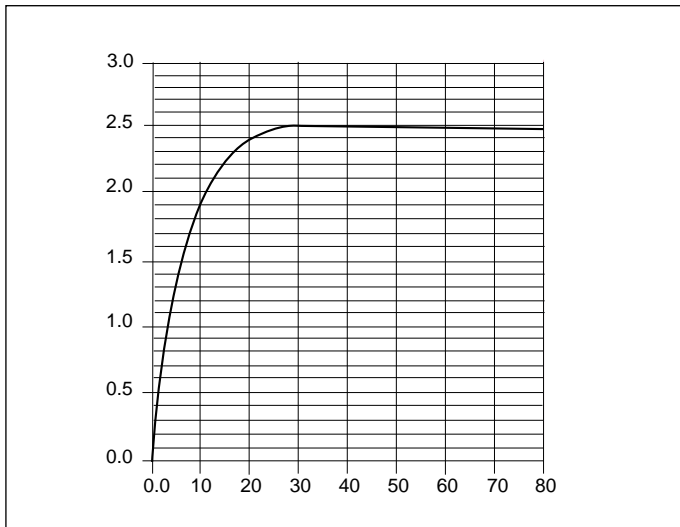

**LINE PRESSURE
 P.S.I. GAUGE**

TUB FILLER FLOWRATE (gpm)

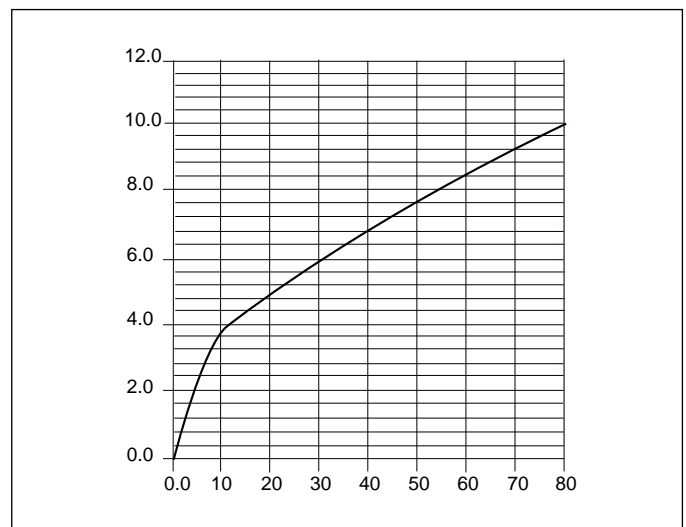

**LINE PRESSURE
 P.S.I. GAUGE**



STRONG. PROFESSIONAL. DESIGN.™