

STERLING®

A KOHLER COMPANY

ACCLAIM™

Features

- Compression molded from our exclusive solid Vikrell® material
- Tongue-and-groove 4-piece modular design allows for easy "snap together" installation
- Durable high-gloss finish
- 5 Jets
- 10-year consumer/3-year commercial limited warranty
- Pump with air switch and grounding-type plug-in cord
- 15" (38.1 cm) bath whirlpool depth (floor to top of threshold)
- 60-1/4" (153 cm) x 31-1/2" (80 cm) x 73-1/2" (186.7 cm) complete unit rough-in dimensions include flange
- 60" (152.4 cm) x 30" (76.2 cm) x 72" (182.9 cm) complete unit finished dimensions

60" (152.4 cm) WHIRLPOOL BATH AND WALL SURROUND

76090110
ALSO 76090120

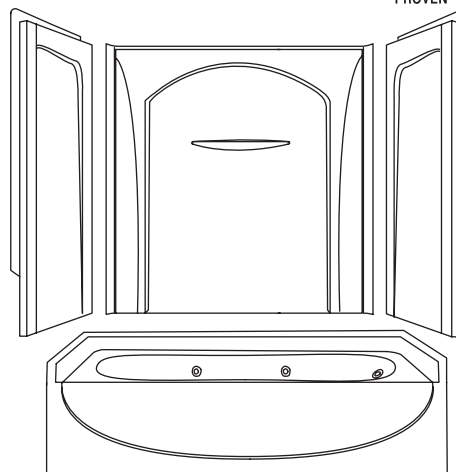

Codes/Standards Applicable

Specified model meets or exceeds the following:

- ASME A112.19.7M
- ANSI Z124.1.2
- NAHB Research Foundation, Inc.
- ASTM E162
- ASTM E662
- UL 1795

Colors/Finishes

- 0: White
- Other: Refer to Price Book for additional colors/finishes

Specified Model

Model	Complete Unit Description	Colors/Finishes	
76090110	60" (152.4 cm) whirlpool bath and wall surround, left drain	<input type="checkbox"/> 0	<input type="checkbox"/> Other _____
76090120	60" (152.4 cm) whirlpool bath and wall surround, right drain	<input type="checkbox"/> 0	<input type="checkbox"/> Other _____

Model	Wall Component Description	Colors/Finishes	
71092100	Back wall	<input type="checkbox"/> 0	<input type="checkbox"/> Other _____
71093110	Left end wall	<input type="checkbox"/> 0	<input type="checkbox"/> Other _____
71093120	Right end wall	<input type="checkbox"/> 0	<input type="checkbox"/> Other _____
71094100	Complete wall set	<input type="checkbox"/> 0	<input type="checkbox"/> Other _____
71095100	End wall set	<input type="checkbox"/> 0	<input type="checkbox"/> Other _____

Technical Information

Fixture*:	
Basin area:	
Bathing well	44" (111.8 cm) x 16" (40.6 cm)
Top area	56" (142.2 cm) x 23-1/2" (59.7 cm)
To overflow:	
Water depth	12" (30.5 cm)
Capacity	34 gal (128.7 L)
* Approximate measurements for comparison only.	

Pump:	V	Hz	A
1-speed	120	60	7

Model	door maximum width	door maximum height
76090110	58-1/2" (148.6 cm)	56-1/2" (143.5 cm)
76090120		
* Varies with alternative walls.		

Required Electrical Service

Dedicated circuit required, protected with Class A Ground-Fault Circuit-Interrupter (GFCI):	
Pump	120 V, 15 A, 60 Hz

Installation Notes

Install this product according to the installation guide.

Pump is supplied with a grounding-type plug-in cord. Locate the outlet behind the whirlpool, and within 24" (61 cm) of the pump.

Pump access opening is required.

Do not disassemble the pump or piping as this could void the warranty.

Size the drain cutout to fit the drain assembly that will be used.

Studs should be positioned roughly as shown.

Adjacent finished wall thickness must not exceed 9/16" (1.4 cm).

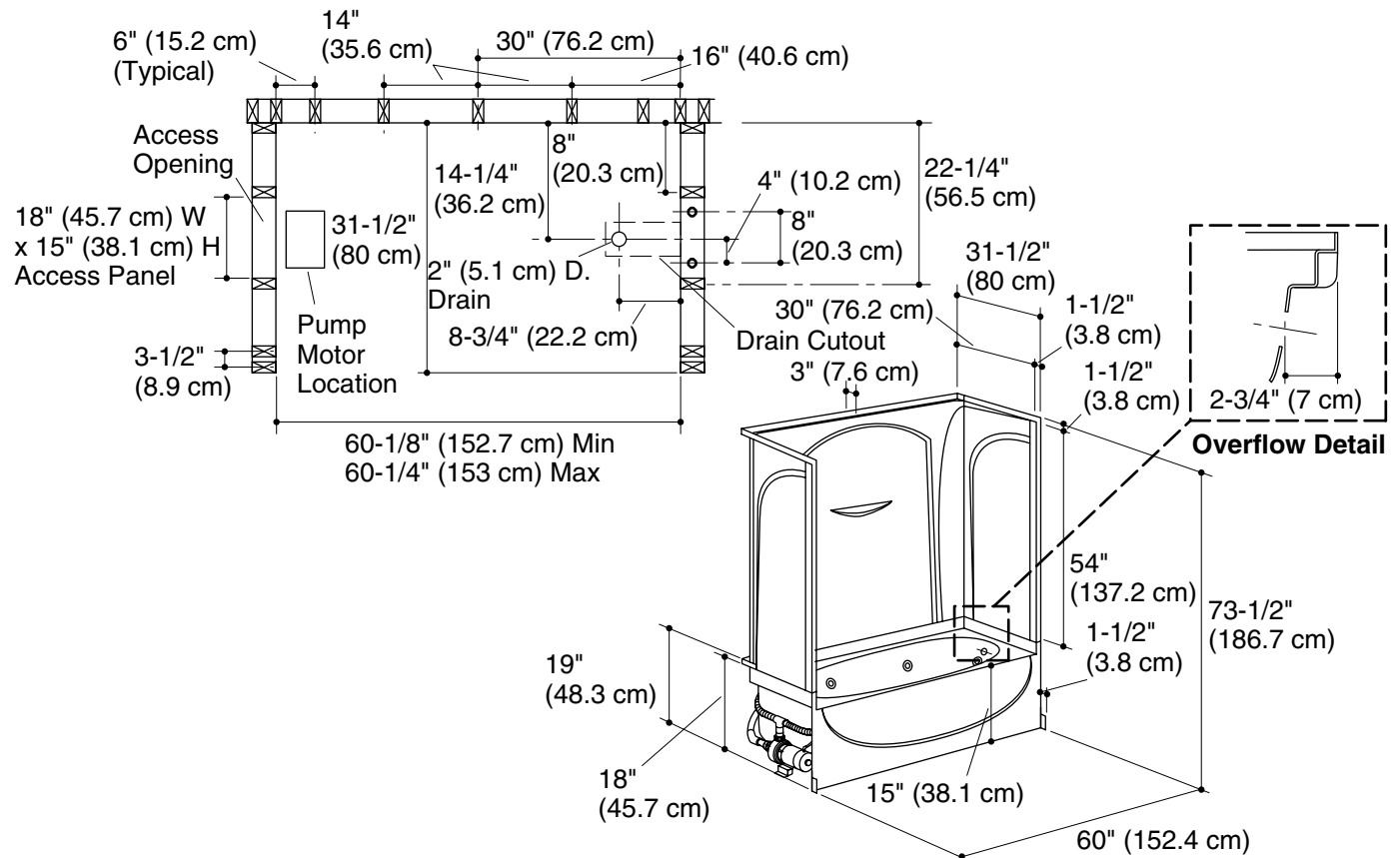

Product Diagram